

R60

Polymeric Positive Temperature Coefficient (PPTC)

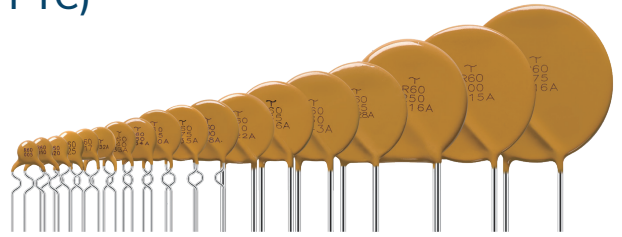

Agency Approvals

Agency	Agency File Number
UL	E201504 / E319079
TUV	R50274672

Packaging

Packaging Option	Applicable Products	Quantity
Bulk	All	500 pieces per box
Reel Pack	R60-010 to R60-090	3,000 pieces per box
	R60-017	2,500 pieces per box
	R60-110 to R60-185	1,500 pieces per box
	R60-250 to R60-375	-

Electrical Properties

Model	V _{max} (VDC) ¹	I _{max} (A) ²	I _{hold} at 25°C (A) ³	I _{trip} at 25°C (A) ⁴	P _d max (W) ⁵	Maximum Time to Trip		Resistance			Agency Approval	
						Current (A)	Time (Sec)	R _i min (Ω) ⁶	R _i max (Ω) ⁶	R ₁ max (Ω) ⁷	UL	TUV-PS
R60-010	60	40	0.10	0.20	0.38	0.50	4.0	2.50	4.50	7.50	•	•
R60-017	60	40	0.17	0.34	0.48	0.85	3.0	2.50	5.21	8.00	•	•
R60-020	60	40	0.20	0.40	0.41	1.00	2.2	1.25	2.75	4.40	•	•
R60-025	60	40	0.25	0.50	0.45	1.25	2.5	0.65	1.95	3.00	•	•
R60-030	60	40	0.30	0.60	0.49	1.50	3.0	0.45	1.33	2.10	•	•
R60-040	60	40	0.40	0.80	0.56	2.00	3.8	0.40	0.86	1.29	•	•
R60-050	60	40	0.50	1.00	0.77	2.50	4.0	0.35	0.77	1.17	•	•
R60-065	60	40	0.65	1.30	0.88	3.25	5.3	0.25	0.48	0.72	•	•
R60-075	60	40	0.75	1.50	0.92	3.75	6.3	0.20	0.40	0.60	•	•
R60-090	60	40	0.90	1.80	0.99	4.50	7.2	0.15	0.31	0.47	•	•
R60-110	60	40	1.10	2.20	1.50	5.50	8.2	0.13	0.25	0.38	•	•
R60-135	60	40	1.35	2.70	1.70	6.75	9.6	0.10	0.19	0.30	•	•
R60-160	60	40	1.60	3.20	1.90	8.00	11.4	0.07	0.14	0.22	•	•
R60-185	60	40	1.85	3.70	2.10	9.25	12.6	0.06	0.12	0.19	•	•
R60-250	60	40	2.50	5.00	2.50	12.50	15.6	0.04	0.08	0.13	•	•
R60-300	60	40	3.00	6.00	2.80	15.00	19.8	0.03	0.06	0.10	•	•
R60-375	60	40	3.75	7.50	3.20	18.75	24.0	0.02	0.05	0.08	•	•

- V_{max} = Maximum voltage device can withstand without damage at rated current (I_{max})
- I_{max} = Maximum fault current device can withstand without damage at rated voltage (V_{max})
- I_{hold} = hold current: maximum current device will sustain for 4 hours without tripping (at 25 °C, still air)
- I_{trip} = trip current: minimum current at which the device will trip (at 25 °C, still air)
- P_d = power dissipated from device when in the tripped state (at 25 °C, still air)
- R_imin/max = minimum/maximum resistance of device in initial (un-soldered) state
- R₁max = maximum resistance of device at 25 °C, measured one hour after tripping

CAUTION: operation beyond the specified ratings may result in damage and possible arcing and flame

Product Characteristics

Operating Temperature	-40 °C to +85 °C
Maximum Device Surface Temperature	In Tripped State, 125 °C
Passive Aging	85 °C, 1000 hours, ±5% Typical Resistance Change
Humidity Aging	85 °C, 85% R.H., 1000 hours, ±5% Typical Resistance Change
Thermal Shock	+85 °C to -40 °C, 20 times, ±10% Typical Resistance Change
Vibration	MIL-STD-202, Method 201, 1 No Change

Mechanical Dimensions

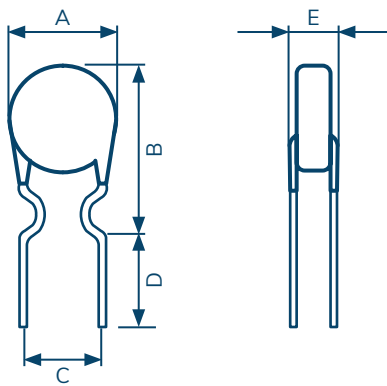

Physical Dimension

Model	Material	Physical Dimensions (Unit: mm/In)					Lead Style
		A (Max.)	B (Max.)	C (Typ.)	D (Min.)	E (Max.)	
R60-010	Tin Plated Copper alloy, 0.205mm ² (24AWG), Ø0.51mm (0.020 in).	7.4 / 0.29	12.7 / 0.50	5.1 / 0.2	7.6 / 0.3	3.1 / 0.12	Kink
R60-017	Tin Plated Copper-Clad Steel, 0.205mm ² (24AWG), Ø0.51mm (0.020 in)	7.4 / 0.29	12.7 / 0.50	5.1 / 0.2	7.6 / 0.3	3.1 / 0.12	Kink
R60-020		7.4 / 0.29	12.7 / 0.48	5.1 / 0.2	7.6 / 0.3	3.1 / 0.12	Kink
R60-025		7.4 / 0.29	12.7 / 0.50	5.1 / 0.2	7.6 / 0.3	3.1 / 0.12	Kink
R60-030		7.4 / 0.29	13.0 / 0.51	5.1 / 0.2	7.6 / 0.3	3.1 / 0.12	Kink
R60-040		7.6 / 0.30	13.5 / 0.53	5.1 / 0.2	7.6 / 0.3	3.1 / 0.12	Kink
R60-050	Tin Plated Copper, 0.205mm ² (24AWG), Ø0.51mm (0.020 in)	7.9 / 0.31	13.7 / 0.54	5.1 / 0.2	7.6 / 0.3	3.1 / 0.12	Kink
R60-065		9.7 / 0.38	14.5 / 0.57	5.1 / 0.2	7.6 / 0.3	3.1 / 0.12	Kink
R60-075		10.4 / 0.41	15.2 / 0.60	5.1 / 0.2	7.6 / 0.3	3.1 / 0.12	Kink
R60-090		11.7 / 0.46	15.8 / 0.62	5.1 / 0.2	7.6 / 0.3	3.1 / 0.12	Kink
R60-110	Tin Plated Copper, 0.52mm ² (20AWG), Ø0.81mm (0.032 in)	13.0 / 0.51	18.0 / 0.71	5.1 / 0.2	7.6 / 0.3	3.1 / 0.12	Straight
R60-135		14.5 / 0.57	19.6 / 0.77	5.1 / 0.2	7.6 / 0.3	3.1 / 0.12	Straight
R60-160		16.3 / 0.64	21.3 / 0.84	5.1 / 0.2	7.6 / 0.3	3.1 / 0.12	Straight
R60-185		17.8 / 0.70	22.9 / 0.90	5.1 / 0.2	7.6 / 0.3	3.1 / 0.12	Straight
R60-250		21.3 / 0.84	26.4 / 1.04	10.2 / 0.4	7.6 / 0.3	3.1 / 0.12	Straight
R60-300		24.9 / 0.98	30.0 / 1.18	10.2 / 0.4	7.6 / 0.3	3.1 / 0.12	Straight
R60-375		28.5 / 1.12	33.5 / 1.32	10.2 / 0.4	7.6 / 0.3	3.1 / 0.12	Straight